**COGENT***"ALWAYS COMPLETE"*

Cogent Computer Systems, Inc.

17 Industrial Drive, Smithfield RI 02917**tel: 401-349-3999, fax: 401-349-3998, web: www.cogcomp.com**

CSB1780 - MPC8536E System On a Module (SOM)

The CSB1780, designed, developed and manufactured by Cogent Computer Systems, Inc., is a high performance, network oriented, PowerPC based System on a Module (SOM). The CSB1780 provides a small, powerful and flexible engine for embedded Linux based 10/100/1000 networking applications of all kinds.

Specifications and Features

- **CPU** - 1.25Ghz e500v2 PowerPC Core
- **CACHE** - 32KByte Instruction and Data Caches, plus On-Chip 512KByte L2 Cache
- **FPU** - IEEE 754 Compliant Floating Point Unit and Signal Processing Engine (SPE)
- **SDRAM** - 512MByte (1GByte Option) 64-Bit Wide DDR2-533 Memory with 8-Bit ECC
- **FLASH** - On-Board 64MByte NOR and 512MByte SLC NAND
- **SD/MMC** - 4-Bit SD/MMC Port, Supports up to 2GB Cards (socket is off module)
- **PCI EXPRESS** - Two x4 Links (may also be configured as one x4 and two x2's)
- **GIGABIT ETHERNET** - Two Dual Mode Copper/SERDES (Auto Selected via PHY) Ports
- **SECURITY** - On-Chip Offload Engines Support Various Encryption/Decryption Algorithms including: IPsec/SSL; DES/3DES; MD-5 and SHA1 hashing; Kasumi f8 and f9; and others
- **XOR/RAID** - High Speed XOR DMA Engine for RAID Storage Applications
- **SATA** - Dual SATA Gen 2 (1.5Gbit or 3Gbit/sec) Channels
- **USB** - Two 480Mbit USB 2.0 Host Ports via Low Power ULPI PHY's
- **SERIAL I/O** - Two 4-wire TTL Serial Ports, Two I2C Port and one SPI with 4 Chip Selects
- **JTAG** - Standard PowerPC JTAG (Header located off module)
- **OPERATING VOLTAGE** - Requires Single +12V Input Rail; On-Board 3.3V (for I/O with 3Amp available to off board devices), 1.8V (SDRAM), 1.0V (CPU Core) Power Supplies
- **POWER MANAGEMENT** - On-Board ATMEGA Microcontroller for Power Sequencing, Boot Configuration, FAN Control and Thermal Monitoring; supports MPC8536e Low Power JOG Mode
- **OPERATING TEMPERATURE** - 0C to +70C Standard, -20C to +85C Option
- **POWER CONSUMPTION** - 8W typ., 12W Max and <10mw Power Down (via 3.3V Standby rail)
- **COGENT MXM SOM COMPLIANT** - Common, Interchangeable Footprint across Multiple CPU Architectures; Designed for Conductive or Air-Cooled Thermal Management; Uses Low Cost (<\$2) Industry Standard MXM-II Socket; Future Versions will Support PCIe GEN-II and XAUI
- **ULTRA COMPACT SIZE** - 70mm x 75mm x 6mm high (Using 4.3mm Low Profile MXM Socket)
- **BOOTLOADER AND OS SUPPORT** - Uboot, Linux 2.6.x and Android 1.5 Cupcake

Introduction and Overview

The high-performance Superscalar e500 Power Architecture Core, multiple PCI Express links, high speed USB, Dual Serial ATA, Dual 10/100/1000 Ethernet, and highly efficient on-board regulators all combine to make the CSB1780 the ideal engine for size restricted, high performance, Gigabit Ethernet based applications. For the lowest power consumption, the IPM Micro can power the board down completely while remaining on standby power. In this mode the consumption drops to <10milliwatts with IPM bus wakeup events still active. The IPM Micro also controls power sequencing; thermal and voltage monitoring; FAN Control; and boot configuration.

The CSB1780 is constructed using state of the art PCB layout and packaging technology such as: 533Mhz DDR2 balanced tree routing; 3GHZ+ high-speed differential signaling; 15 Amp peak switching regulators; and 8-layer, low EMI, impedance controlled PCB stackup. The CSB1780 gives you access to this technology without the learning curve or the risk. You can integrate the CSB1780 using a simple, low cost 4-layer PCB, in just weeks, not months! We can even do it for you through our custom design services group.

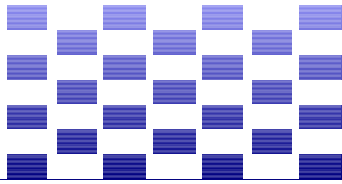

COGENT

"ALWAYS COMPLETE"

Cogent Computer Systems, Inc.

17 Industrial Drive, Smithfield RI 02917

tel: 401-349-3999, fax: 401-349-3998, web: www.cogcomp.com

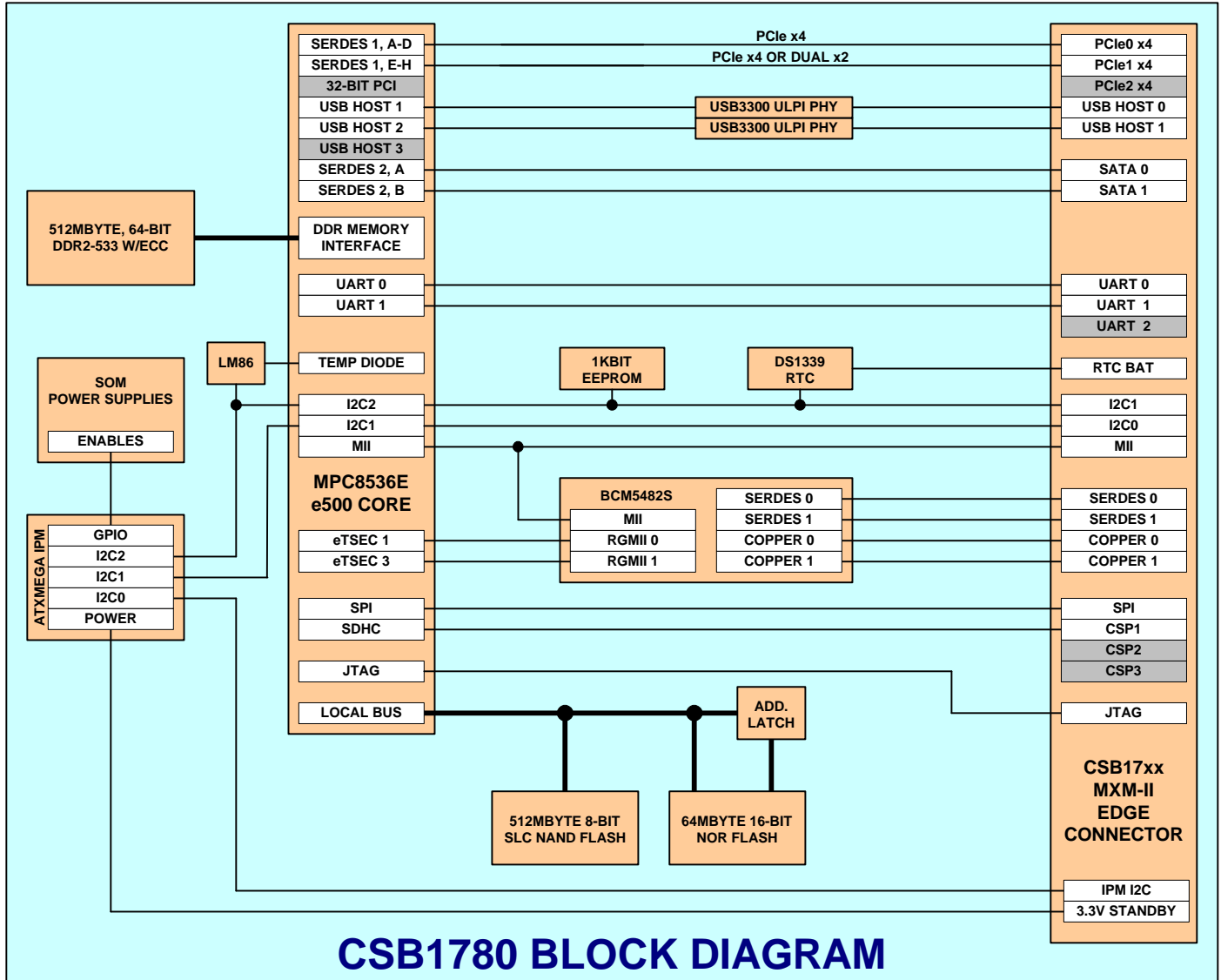

Development Boards and I/O Expansion

The CSB1780 is fully compatible with the CSB1701 Flex-ATX Development Platform. This platform provides a CSB17xx compatible MXM Socket, Three CPU I/O Expansion Headers; Two RS-232 COM Ports; Dual 10/100/1000 Ethernet; Dual SATA Connectors and Dual USB Host Connectors facilitate self-hosted Linux development. This platform also provides four PCIe Slots (lanes per socket are CPU specific). The KIT1780 consists of the CSB1780 and the CSB1701 installed in a compact (12.7" x 11" x 5.5"), Micro-ATX Case with 300W Power Supply. Contact Cogent for more detailed information about the CSB1701 and the KIT1780 Development Kit.